



2016 Saker Series Product Brochure

The Saker Series is an electric projection screen that embodies all the virtues of quality, durability, and aesthetic value. It utilizes our MaxWhite FG material which has a wide viewing angle to allow the audience to see the image from anywhere in the room



Saker Series



The Saker Series is an electric projection screen that embodies all the virtues of quality, durability, and aesthetic value. It utilizes our MaxWhite FG material which has a wide viewing angle to allow the audience to see the image from anywhere in the room



Screen Material:

- MaxWhite Fiberglass (1.1 Gain) matte white fiberglass-backed material
- Wide viewing angle and uniformly diffuses light in all directions
- Active 3D and 4K Ultra HD Ready
- Standard black masking borders and black screen backing
- Flame Retardant: Complies with NFPA 701 standards

Design and Installation:

- Arcuate profile aluminum enamel white case with parallel grooves
- Mounting hardware kit included for wall or ceiling installations
- Extra top black masking border for high ceiling installations
- Flush hidden wall mounts allow screen to slide horizontally for proper centering
- Plug & Play ready, no hardwire installation required

Control System:

- Internal Radio Frequency/Infrared receivers with IR, RF remotes included
- Detachable 3-way wall switch keypad for UP/STOP/DOWN manual operation
- Wireless 5-12 volt trigger included
- RJ45 port allows 3rd party control system integration

Quality and Reliability:

- Synchronous motor has silent operation and low power consumption
- GREENGUARD® and GREENGUARD® Gold Certified UL | 2818
- 2-year limited manufacturer's warranty
- 3-year warranty offered through ENR-G program (Education, Non-profit, Religious, and Government/Military)

Saker Series

Model	Screen Diag. & Aspect Ratio	View Height (in)	View Width (in)	View Height (cm)	View Width (cm)	N.W. (lbs.)	G.W. (lbs.)	N.W. (kgs)	G.W. (Kgs)	Packaging Dimensions (LxHxW)	Gain	Screen Material	Case Color
SK100XVW-E10*	100" (4:3)	60	80	152.4	203.2	24.2	32.5	11.0	14.7	98.5"x6.3"x6.7"	1.1	MaxWhite FG	White
SK110XVW-E10*	110" (4:3)	66	88	167.6	223.5	27.8	36.6	12.6	16.6	107.3"x6.3"x6.7"	1.1	MaxWhite FG	White
SK120XVW-E9*	120" (4:3)	72	96	182.9	243.8	29.9	38.6	13.6	17.5	114.3"x6.3"x6.7"	1.1	MaxWhite FG	White
SK135XVW-E6*	135" (4:3)	81	108	205.7	274.3	33.1	42.5	15.0	19.3	127.2"x6.3"x6.7"	1.1	MaxWhite FG	White
SK180XVW2-E4	180" (4:3)	108	144	274.3	365.8	57.9	75.7	26.2	34.3	161"x7.9"x8.5"	1.1	MaxWhite FG	White
SK84XHW-E24	84" (16:9)	41.2	73.2	104.6	185.9	22.4	30.2	10.2	13.7	99.4"x6.3"x6.7"	1.1	MaxWhite FG	White
SK92XHW-E24*	92" (16:9)	45.1	80.2	114.5	203.7	25	32.3	11.4	14.7	99.4"x6.3"x6.7"	1.1	MaxWhite FG	White
SK100XHW-E12*	100" (16:9)	49	87.2	124.5	221.4	25.1	33.9	11.4	15.4	106.57"x6.3"x6.7"	1.1	MaxWhite FG	White
SK100XHW-E24	100" (16:9)	49	87.2	124.5	221.4	26.3	34.7	11.9	15.8	106.57"x6.3"x6.7"	1.1	MaxWhite FG	White
SK110XHW-E12*	110" (16:9)	53.9	95.9	136.9	243.6	28.6	37.7	13.0	17.1	114.32"x6.3"x6.7"	1.1	MaxWhite FG	White
SK110XHW-E24	110" (16:9)	53.9	95.9	136.9	243.6	29.5	38.9	13.0	17.7	114.32"x6.3"x6.7"	1.1	MaxWhite FG	White
SK120XHW-E10*	120" (16:9)	58.8	104.6	149.6	265.4	30.8	40.1	14.0	18.2	122.28"x6.3"x6.7"	1.1	MaxWhite FG	White
SK120XHW-E20	120" (16:9)	58.8	104.6	149.6	265.4	31.8	41.2	14.4	18.7	122.28"x6.3"x6.7"	1.1	MaxWhite FG	White
SK135XHW-E6*	135" (16:9)	66.2	117.7	168.1	299.0	34.9	44.3	15.8	20.1	137.2"x6.3"x6.7"	1.1	MaxWhite FG	White
SK135XHW-E18	135" (16:9)	66.2	117.7	168.1	299.0	34.9	44.3	15.8	20.1	137.2"x6.3"x6.7"	1.1	MaxWhite FG	White
SK150XHW-E12	150" (16:9)	73.5	130.7	186.9	331.9	50.3	66.9	22.8	30.3	148.3"x8.5"x8.8"	1.1	MaxWhite FG	White
SK180XHW2-E12	180" (16:9)	88.3	156.9	224.3	398.5	60.7	79.5	27.5	36.1	174.4"x7.9"x8.5"	1.1	MaxWhite FG	White
SK100NXW-E24	100" (16:10)	53	84.8	134.6	215.4	26.5	34.6	12.0	15.7	104.13"x6.3"x6.7"	1.1	MaxWhite FG	White
SK110NXW-E10*	110" (16:10)	58.3	93.3	148.1	237.0	29.6	37.0	13.4	16.8	110.6"x6.3"x6.7"	1.1	MaxWhite FG	White
SK120NXW-E12	120" (16:10)	63.6	101.8	161.5	258.6	31.2	40.3	14.1	18.3	121.3"x6.3"x6.7"	1.1	MaxWhite FG	White
SK135NXW-E6*	135" (16:10)	71.5	114.5	181.6	290.8	33.5	43.7	15.2	19.8	133.6"x6.3"x6.7"	1.1	MaxWhite FG	White

*Only available in certain regions

Saker Series Dimensions Table (180" Models)

Model	Screen Diag. & Aspect Ratio	Overall L with Bracket (A)	View Width (A1)	End Cap Screw Hole Distance (A2)	Overall L without Bracket (A3)	Ceiling Bracket Hole Distance (A4)	Screen Width (A5)	Weight Bar Length (A6)	L/R Border (A7)	Overall H with Ceiling Bracket (B)	View Height (B1)	Screen Height (B2)	Top Black Masking (B3)	Bottom Border (B4)	End Cap H. w/ Bracket (B5)	End Cap W. with Ceiling Bracket (C)	End Cap H. w/ Ceiling Bracket (C1)	(C2)	Weight Bar Diameter (C3)
SK180XVW2-E4	180" (4:3)	4013	3658	3977	3943	3143	3758	3838	50	3030	2743	2905	102	60	118	118	125	35	23
SK180XHW2-E12	180" (16:9)	4345	3985	4309	4275	3475	4085	4165	50	2732	2242	2607	305	60	118	118	125	35	23

Unit: mm

*Only available in certain regions

Model	Screen Diag. & Aspect Ratio	Overall L with Bracket (A)	View Width (A1)	End Cap Screw Hole Distance (A2)	Overall L without Bracket (A3)	Ceiling Bracket Hole Distance (A4)	Screen Width (A5)	Weight Bar Length (A6)	L/R Border (A7)	Overall H with Ceiling Bracket (B)	View Height (B1)	Screen Height (B2)	Top Black Masking (B3)	Bottom Border (B4)	End Cap H. w/ Bracket (B5)	End Cap W. with Ceiling Bracket (C)	End Cap H. w/ Ceiling Bracket (C1)	(C2)	Weight Bar Diameter (C3)
SK180XVW2-E4	180" (4:3)	158.0	144.0	156.6	155.2	123.7	148.0	151.1	2.0	119.3	108.0	114.4	4.0	2.4	4.6	4.6	4.9	1.4	0.9
SK180XHW2-E12	180" (16:9)	171.1	156.9	169.6	168.3	136.8	160.8	164.0	2.0	107.6	88.3	102.6	12.0	2.4	4.6	4.6	4.9	1.4	0.9

Unit: inch

*Only available in certain regions

Note: Data Error ±1". The listed measurements are for general reference only. Please contact Elite Screens to verify product design and dimensions before attempting to integrate its products with any structural or furniture modification. Although a manufacturer may offer product advice, it may be taken or disregarded at the integrator's discretion. Elite Screens will not be held responsible or be otherwise liable for faulty installations.

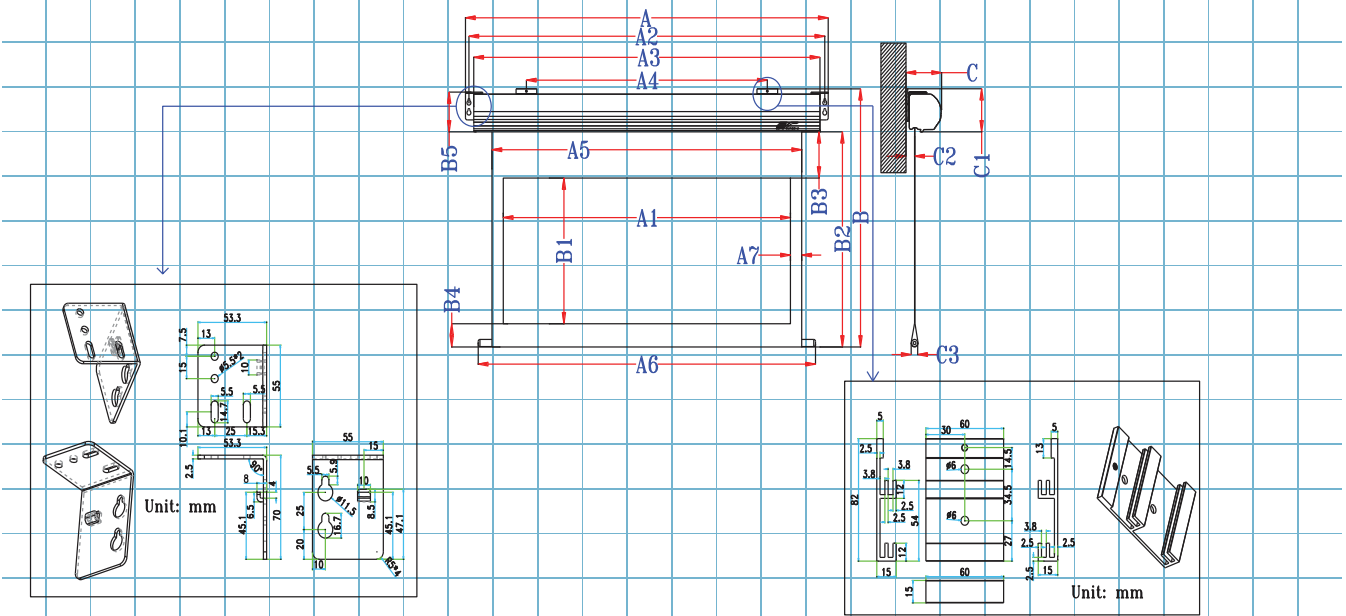

Saker Series Dimensions Table

Model	Screen Diag. & Aspect Ratio	Overall L with Bracket (A)	View Width (A1)	End Cap Screw Hole Distance (A2)	Overall L without Bracket (A3)	Ceiling Bracket Hole Distance (A4)	Screen Width (A5)	Weight Bar Length (A6)	L/R Border (A7)	Overall H with Ceiling Bracket (B)	View Height (B1)	Screen Height (B2)	Top Black Masking (B3)	Bottom Border (B4)	End Cap H. w/ Bracket (B5)	End Cap W. with Ceiling Bracket (C)	End Cap H. w/ Ceiling Bracket (C1)	(C2)	Weight Bar Diameter (C3)
SK100XVW-E10*	100*(4:3)	2376	2032	2356	2330	1530	2132	2212	50	1946	1524	1838	254	60	100	102	108	35	23
SK110XVW-E10*	110*(4:3)	2578	2235	2558	2532	1732	2335	2415	50	2098	1676	1990	254	60	100	102	108	35	23
SK120XVW-E9*	120*(4:3)	2783	2438	2763	2737	1937	2538	2618	50	2226	1829	2118	229	60	100	102	108	35	23
SK135XVW-E6*	135*(4:3)	3086	2743	3066	3040	2240	2843	2923	50	2377	2057	2269	152	60	100	102	108	35	23
SK84XHW-E24	84*(16:9)	2178	1860	2158	2132	1332	1936	2016	38	1824	1046	1716	610	60	100	102	108	35	23
SK92XHW-E24*	92*(16:9)	2376	2037	2356	2330	1530	2137	2217	50	1924	1146	1816	610	60	100	102	108	35	23
SK100XHW-E12*	100*(16:9)	2557	2214	2537	2511	1711	2314	2394	50	1718	1245	1610	305	60	100	102	108	35	23
SK100XHW-E24	100*(16:9)	2557	2214	2537	2511	1711	2314	2394	50	2023	1245	1915	610	60	100	102	108	35	23
SK110XHW-E12*	110*(16:9)	2783	2435	2763	2737	1937	2535	2615	50	1843	1370	1735	305	60	100	102	108	35	23
SK110XHW-E24	110*(16:9)	2783	2435	2763	2737	1937	2535	2615	50	2148	1370	2040	610	60	100	102	108	35	23
SK120XHW-E10*	120*(16:9)	3001	2657	2981	2955	2155	2757	2837	50	1916	1494	1808	254	60	100	102	108	35	23
SK120XHW-E20	120*(16:9)	3001	2657	2981	2955	2155	2757	2837	50	2170	1494	2062	508	60	100	102	108	35	23
SK135XHW-E6*	135*(16:9)	3332	2989	3312	3286	2486	3089	3169	50	2001	1681	1893	152	60	100	102	108	35	23
SK135XHW-E18	135*(16:9)	3332	2989	3312	3286	2486	3089	3169	50	2306	1681	2198	457	60	100	102	108	35	23
SK135XHW-E12	150*(16:9)	3666	3321	3646	3620	2820	3421	3501	50	2341	1868	2233	305	60	100	102	108	35	23
SK100NXW-E24	100*(16:10)	2497	2154	2477	2451	1651	2256	2336	51	2124	1346	2016	610	60	100	102	108	35	23
SK110NXW-E10*	110*(16:10)	2711	2369	2691	2665	1865	2469	2549	50	1903	1481	1795	254	60	100	102	108	35	23
SK120NXW-E12	120*(16:10)	2929	2585	2909	2883	2083	2685	2765	50	2088	1615	1980	305	60	100	102	108	35	23
SK135NXW-E6*	135*(16:10)	3251	2908	3231	3205	2405	3008	3088	50	2137	1817	2029	152	60	100	102	108	35	23

Unit: mm

*Only available in certain regions

Model	Screen Diag. & Aspect Ratio	Overall L with Bracket (A)	View Width (A1)	End Cap Screw Hole Distance (A2)	Overall L without Bracket (A3)	Ceiling Bracket Hole Distance (A4)	Screen Width (A5)	Weight Bar Length (A6)	L/R Border (A7)	Overall H with Ceiling Bracket (B)	View Height (B1)	Screen Height (B2)	Top Black Masking (B3)	Bottom Border (B4)	End Cap H. w/ Bracket (B5)	End Cap W. with Ceiling Bracket (C)	End Cap H. w/ Ceiling Bracket (C1)	(C2)	Weight Bar Diameter (C3)
SK100XVW-E10*	100*(4:3)	93.5	80.0	92.8	91.7	60.2	83.9	87.1	2.0	76.6	60.0	72.4	10.0	2.4	3.9	4.0	4.3	1.4	0.9
SK110XVW-E10*	110*(4:3)	101.5	88.0	100.7	99.7	68.2	91.9	95.1	2.0	82.6	66.0	78.3	10.0	2.4	3.9	4.0	4.3	1.4	0.9
SK120XVW-E9*	120*(4:3)	109.6	96.0	108.8	107.8	76.3	99.9	103.1	2.0	87.6	72.0	83.4	9.0	2.4	3.9	4.0	4.3	1.4	0.9
SK135XVW-E6*	135*(4:3)	121.5	108.0	120.7	119.7	88.2	111.9	115.1	2.0	93.6	81.0	89.3	6.0	2.4	3.9	4.0	4.3	1.4	0.9
SK84XHW-E24	84*(16:9)	85.7	73.2	85.0	83.9	52.4	76.2	79.4	1.5	71.8	41.2	67.6	24.0	2.4	3.9	4.0	4.3	1.4	0.9
SK92XHW-E24*	92*(16:9)	93.5	80.2	92.8	91.7	60.2	84.1	87.3	2.0	75.7	45.1	71.5	24.0	2.4	3.9	4.0	4.3	1.4	0.9
SK100XHW-E12*	100*(16:9)	100.7	87.2	99.9	98.9	67.4	91.1	94.3	2.0	67.6	49.0	63.4	12.0	2.4	3.9	4.0	4.3	1.4	0.9
SK100XHW-E24	100*(16:9)	100.7	87.2	99.9	98.9	67.4	91.1	94.3	2.0	79.6	49.0	75.4	24.0	2.4	3.9	4.0	4.3	1.4	0.9
SK110XHW-E12*	110*(16:9)	109.6	95.9	108.8	107.8	76.3	99.8	103.0	2.0	72.6	53.9	68.3	12.0	2.4	3.9	4.0	4.3	1.4	0.9
SK110XHW-E24	110*(16:9)	109.6	95.9	108.8	107.8	76.3	99.8	103.0	2.0	84.6	53.9	80.3	24.0	2.4	3.9	4.0	4.3	1.4	0.9
SK120XHW-E10*	120*(16:9)	118.1	104.6	117.4	116.3	84.8	108.5	111.7	2.0	75.4	58.8	71.2	10.0	2.4	3.9	4.0	4.3	1.4	0.9
SK120XHW-E20	120*(16:9)	118.1	104.6	117.4	116.3	84.8	108.5	111.7	2.0	85.4	58.8	81.2	20.0	2.4	3.9	4.0	4.3	1.4	0.9
SK135XHW-E6*	135*(16:9)	131.2	117.7	130.4	129.4	97.9	121.6	124.8	2.0	78.8	66.2	74.5	6.0	2.4	3.9	4.0	4.3	1.4	0.9
SK135XHW-E18	135*(16:9)	131.2	117.7	130.4	129.4	97.9	121.6	124.8	2.0	90.8	66.2	86.5	18.0	2.4	3.9	4.0	4.3	1.4	0.9
SK150XHW-E12	150*(16:9)	144.3	130.7	143.5	142.5	111.0	134.7	137.8	2.0	92.2	73.5	87.9	12.0	2.4	3.9	4.0	4.3	1.4	0.9
SK100NXW-E24	100*(16:10)	98.3	84.8	97.5	96.5	65.0	88.8	92.0	2.0	83.6	53.0	79.4	24.0	2.4	3.9	4.0	4.3	1.4	0.9
SK110NXW-E10*	110*(16:10)	106.7	93.3	105.9	104.9	73.4	97.2	100.4	2.0	74.9	58.3	70.7	10.0	2.4	3.9	4.0	4.3	1.4	0.9
SK120NXW-E12	120*(16:10)	115.3	101.8	114.5	113.5	82.0	105.7	108.9	2.0	82.2	63.6	78.0	12.0	2.4	3.9	4.0	4.3	1.4	0.9
SK135NXW-E6*	135*(16:10)	128.0	114.5	127.2	126.2	94.7	118.4	121.6	2.0	84.1	71.5	79.9	6.0	2.4	3.9	4.0	4.3	1.4	0.9

Unit: inch

*Only available in certain regions

Note: Data Error ±1". The listed measurements are for general reference only. Please contact Elite Screens to verify product design and dimensions before attempting to integrate its products with any structural or furniture modification. Although a manufacturer may offer product advice, it may be taken or disregarded at the integrator's discretion. Elite Screens will not be held responsible or be otherwise liable for faulty installations.

